



Technical Data

# FOLDING UTILITY SHELF

# B-287



Patented

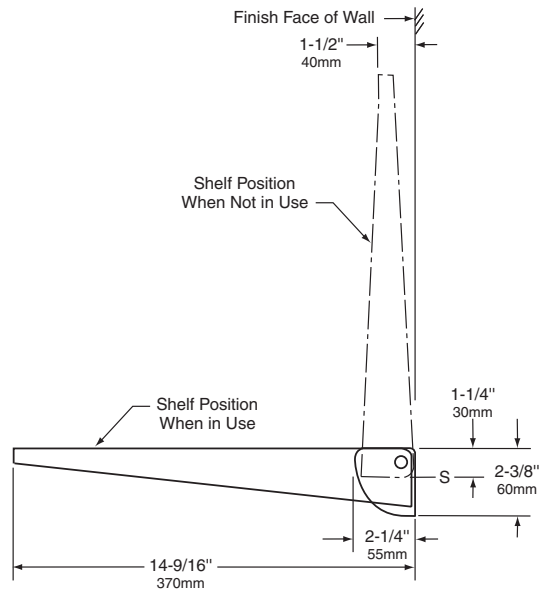
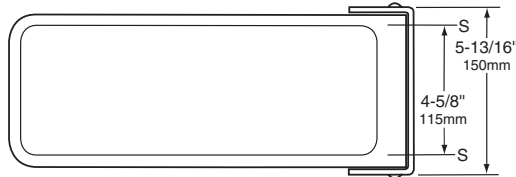

### MATERIALS:

**Shelf** — 18-8 S, type-304, 18-gauge (1.2mm) stainless steel. All-welded construction. Exposed surfaces have satin finish. Equipped with heavy-duty internal spring.

**Mounting Bracket** — 18-8 S, type-304, 18-gauge (1.2mm) stainless steel with satin finish.

### OPERATION:

Shelf automatically returns to upright position when object is removed. Toilet compartment door cannot be opened when shelf is in use.

### INSTALLATION:

Mount unit on wall or toilet partition adjacent to latch side of compartment door with two sheet-metal screws, locknuts, and washers, furnished by manufacturer, at points indicated by an S.

For plaster or dry wall construction, provide concealed backing to comply with local building codes, then secure unit with sheet-metal screws furnished. For other wall surfaces, provide fiber plugs or expansion shields for use with sheet-metal screws furnished, or provide 1/8" (3mm) toggle bolts or expansion bolts.

For partitions with particle-board or other solid core, secure unit with sheet-metal screws furnished or provide through-bolts, nuts, and washers. For hollow-core metal partitions, provide solid backing into which furnished sheet-metal screws can be secured. If two units are installed back-to-back, provide threaded sleeves and machine screws for the full thickness of partition.

**Note:** Provide 5" (125mm) minimum clearance from the inside surface of toilet compartment door to the front edge of shelf to allow door to swing open and close. Provide 14-7/8" (380mm) minimum clearance above the mounting screw holes to the underside of any horizontal projection.

### SPECIFICATION:

Folding utility shelf shall be type-304 stainless steel with all-welded construction; exposed surfaces shall have satin finish. Shelf shall be equipped with a heavy-duty internal spring. Shelf shall automatically return to upright position when not in use. Manufacturer's service and parts manual shall be provided to the building owner/manager upon completion of project.

**Folding Utility Shelf shall be Model B-287 of Bobrick Washroom Equipment, Inc., Clifton Park, New York; Jackson, Tennessee; Los Angeles, California; Bobrick Washroom Equipment Company, Scarborough, Ontario; Bobrick Washroom Equipment Pty. Ltd., Australia; and Bobrick Washroom Equipment Limited, United Kingdom.**