

# SCOT®

## S-60 Series

# Metering Faucet

## S-61 Series

Slow-Closing Omni Temperature Lavatory Faucet & Metering Lavatory Faucet

INSTALLATION, OPERATION AND SERVICE INSTRUCTIONS

### IMPORTANT:

**Water lines MUST be thoroughly flushed BEFORE and AFTER installing the faucet to prevent foreign matter i.e. copper chips, sand, stones, etc. from clogging and possibly damaging the sealing surfaces of the cartridge.**

### INSTALLATION

(Supply stop valves must have a 3/8" O.D. compression outlet.)

1. **S-60 Series:** Remove nut and ferrule from supply stops, install in-line check/screen assembly (LL-71B) on male outlet of stops.
2. Install SPF-KIT loosely on faucet. Position faucet through sink or counter with mounting gasket under base. Secure faucet tightening nuts from under side.
3. Install drain assembly. Seal under flange with putty.
4. **S-60 Series:** Carefully bend copper supplies to meet water supplies using palms of hands to avoid kinking tubing or fracturing solder joints. Connect hot supply to left tube and cold supply to right tube using appropriate lengths of 3/8" O.D. tubing between faucet supplies and in-line check/screen assembly.

**S-61 Series:** Connect cold or tempered supply to faucet supply using appropriate length of 3/8" O.D. tubing between faucet and in-line check/screen assembly.

5. **S-60 Series:** To flush faucet remove aerator (LN-100 or LN-101) and turn valve handle to full cold position. Open supply and depress handle holding down for 10 seconds, rotate handle to hot position, open supply and repeat above procedure. Hold down handle and rotate from left to right to flush lines thoroughly. Allow faucet to shut off and replace aerator.

**S-61 Series:** To flush faucet remove aerator (LN-100 or LN-101) and open supply stop depress handle and hold down for 10 seconds. Repeat several times and allow faucet to shut off. Replace aerator.

### Adjustment of cycle time and temperature

After faucet has been operated through a number of cycles and supply water temperature is at designed levels, adjustments to these features can be made as follows.

**Cycle Time:** To increase time, loosen allen screw (LL-27) with a 3/32" hex socket key, remove handle (LT-100 or LL-104) and remove one or more of the washers (LL-28) on stem. To reduce time, add washers.

### Temperature limit adjustment (S-60 Series only):

Loosen allen screw (LL-27) with a 3/32" hex socket key.

### S-60 Series

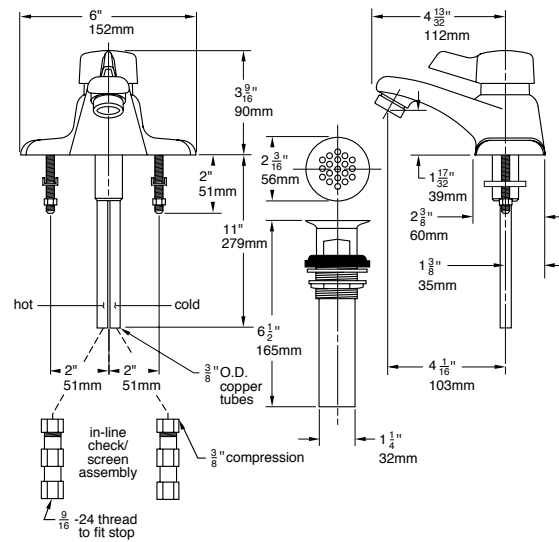

### S-61 Series

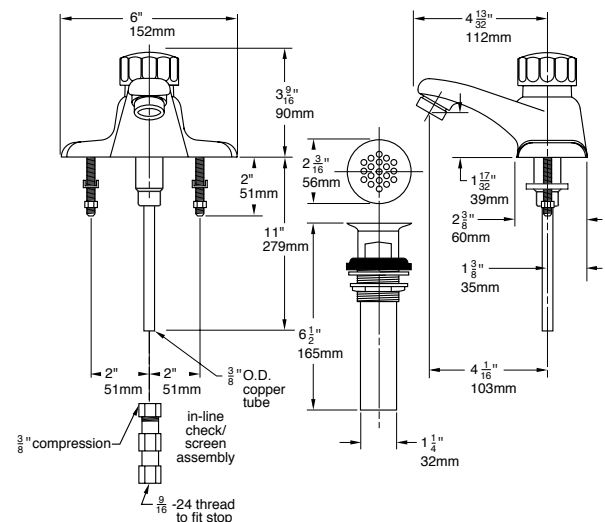

Remove handle (LL-104), loosen nut (LL-6) and turn stem (LL-1A) to desired maximum temperature (110°F recommended). Turn limit stop washer (LL-23N) clockwise until a positive stop is reached against back of faucet. Tighten nut (LL-6), replace and tighten handle (LL-104). Faucet will operate from the full cold position to the maximum hot temperature that has been set.

### Reverse operation (S-60 Series only)

For piping simplicity in back to back installation or when hot supply is on right, the faucet's internal operation can be quickly reversed. Remove handle (LL-104), nut (LL-6), and limit stop washers (LL-22N) & (LL-23N), turn stem 180° so that red marking is facing toward front. Replace limit stop washers, adjust to desired temperature (see adjustment procedure in preceding paragraph), reassemble faucet reversing above procedure. Faucet will operate from the full cold position to the maximum hot temperature that has been set.

# SCOT® S-60 Series

LL-1	Control spindle
LL-1A	Control cartridge
LL-1B	Control cartridge for quick-closing
LL-2A	Cycle spindle assembly
LL-3N	Upper housing
LL-4	Piston washer screw
LL-6	Limit stop retainer nut
LL-8	Cycle spindle guide
LL-11	Piston cylinder
LL-12	Piston
LL-13	Inlet seat
LL-16	Shut-off seat
LL-22N	Limit stop washer (fixed)
LL-23N	Limit stop washer (adjustable)
LL-24	Control rod
LL-27	Handle set screw
LL-28	Cycle time washers
LL-31	Retaining ring
LL-32	Piston spring
LL-33	Inlet seat springs (2)
LL-35	Thrust washer
LL-37	Shut-off washer
LL-42	Inlet seat o-rings (2)
LL-44	Spindle guide large o-ring
LL-45	Shut-off seat o-ring
LL-46	Control spindle small o-ring
LL-47	Control spindle large o-ring
LL-48	Upper housing o-rings (3)
LL-49	Piston o-ring
LL-71B	In-line check/screen assembly (2)
LL-75	Spindle guide huva cup
LL-76	Huva cup retainer
LL-104	Handle
LL-105	Shell
LL-106	Base plate gasket
LL-107	Supply housing
LN-12	Anchor stud
LN-100	Aerator (vandal resistant 0.5 gpm)
LN-101	Aerator (vandal resistant)
LT-4A	Piston assembly
SPF-KIT	Mounting Kit
TT-36	Undercover plate screws (2)

## Tools required for disassembly

Order LL-KIT-W, consisting of:

LL-27W	3/32" hex socket key to remove handle set screw
LL-9W	15/16" socket to remove shell locking nut
LL-60K	Spray outlet wrench to remove spray outlet (included with faucet)

## Other standard tools required:

Adjustable or 11/16" and 3/4" open end wrench, small phillips screwdriver, pliers

## Repair Kit LL consists of:

LL-4, LL-8, LL-13, LL-24, LL-31, LL-32, LL-33, LL-35, LL-37, LL-42, LL-43, LL-44, LL-45, LL-46, LL-47, LL-48, LL-49, LL-73, LL-75, LL-76.

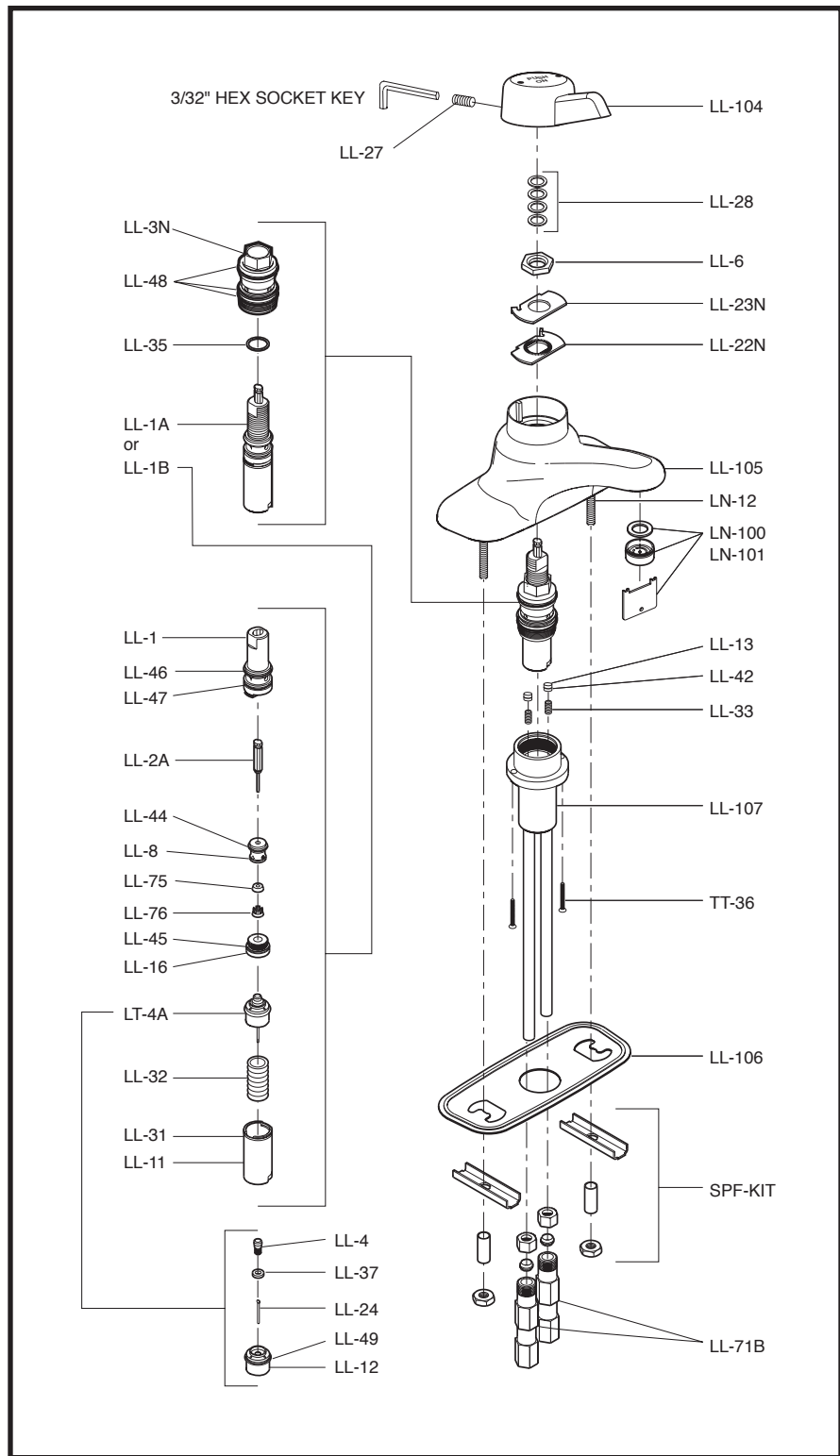

# Metering Faucet S-61 Series

- LL-1 Control spindle
- LL-1A Control cartridge for quick-closing
- LL-1B Control cartridge for quick-closing
- LL-2A Cycle spindle assembly
- LL-3N Upper housing
- LL-4 Piston washer screw
- LL-8 Cycle spindle guide
- LL-11 Piston cylinder
- LL-12 Piston
- LL-16 Shut-off seat
- LL-24 Control rod
- LL-27 Handle set screw
- LL-28 Cycle time washers
- LL-31 Retaining ring
- LL-32 Piston spring
- LL-35 Thrust washer
- LL-37 Shut-off washer
- LL-44 Spindle guide large o-ring
- LL-45 Shut-off seat o-ring
- LL-46 Control spindle small o-ring
- LL-47 Control spindle large o-ring
- LL-48 Upper housing o-rings (3)
- LL-49 Piston o-ring
- LL-75 Spindle guide hupa cup
- LL-76 Hupa cup retainer
- LL-105 Shell
- LL-106 Base plate gasket
- LN-12 Anchor stud
- LN-100 Aerator (vandal resistant 0.5 gpm)
- LN-101 Aerator (vandal resistant)
- LT-4A Piston assembly
- LT-71B In-line check/screen assembly
- LT-100 Handle
- LT-108 Supply housing
- SPF-KIT Mounting Kit
- TT-36 Undercover plate screws (2)

## Tools required for disassembly

Order LL-KIT-W, consisting of:

- LL-27W 3/32" hex socket key to remove handle set screw
- LL-9W 15/16" socket to remove shell locking nut
- LL-60K Spray outlet wrench to remove spray outlet (included with faucet)

## Other standard tools required:

Adjustable or 11/16" and 3/4" open end wrench, small phillips screwdriver, pliers

## Repair Kit LL consists of:

- LL-4, LL-8, LL-13, LL-24, LL-31, LL-32, LL-33, LL-35, LL-37, LL-42, LL-43, LL-44, LL-45, LL-46, LL-47, LL-48, LL-49, LL-73, LL-75, LL-76.

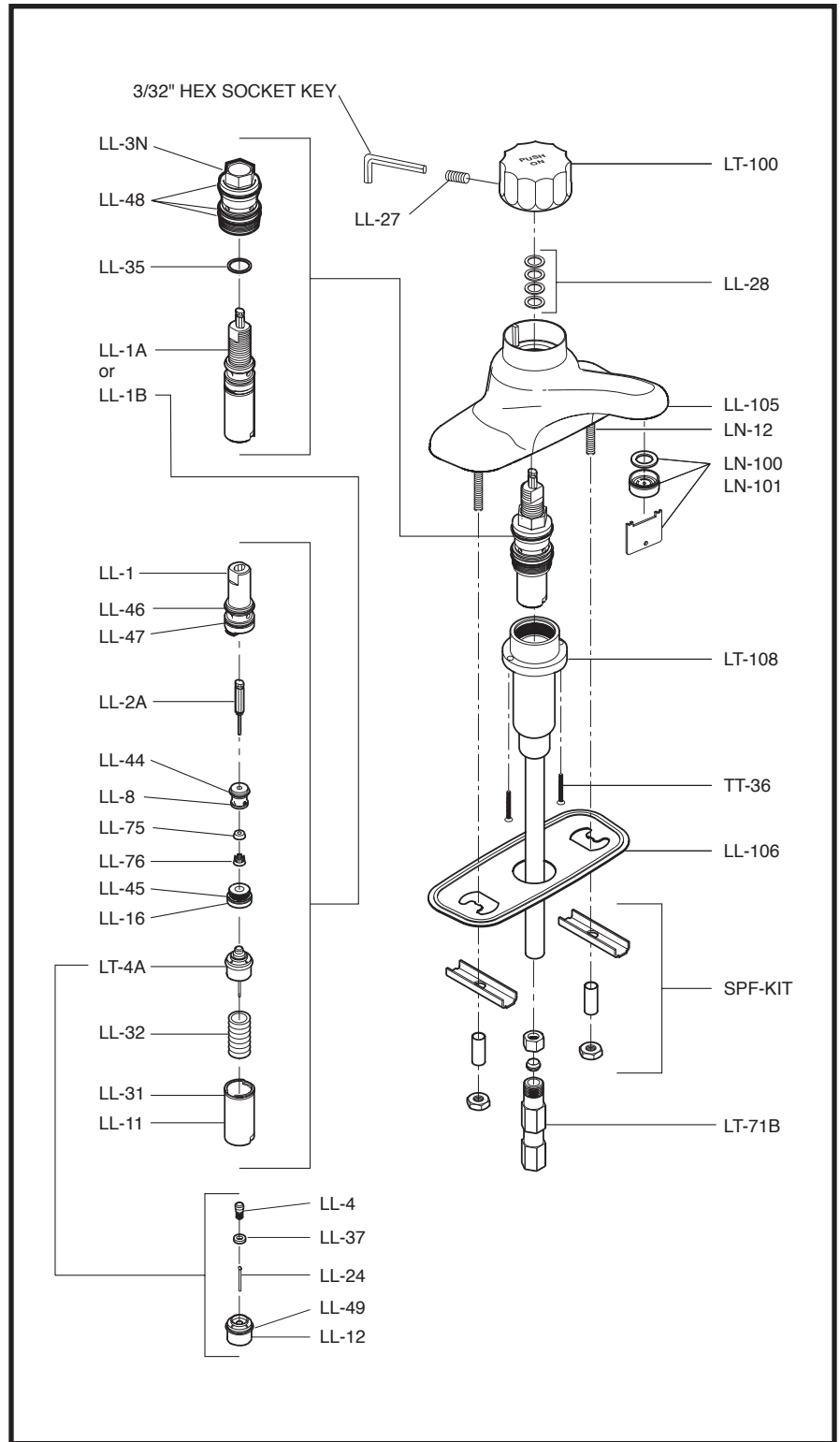

## SERVICE INSTRUCTIONS

- General repair will require the repair or replacement of the cartridge unit.
- Shut off water supply to the faucet.
- Remove handle with 3/32" hex socket key.
- S-60 Series:** Remove cycle time washers (LL-28), limit stop retainer nut (LL-6), and limit stop washers (LL-22N and LL-23N).  
**S-61 Series:** Remove cycle time washers (LL-28).
- S-60 Series:** Remove upper housing (LL-3N) with an adjustable wrench, slide housing off control cartridge (LL-1A).  
**S-61 Series:** Remove upper housing (LL-3N) with an adjustable wrench, slide housing off control cartridge (LL-1A).
- S-60 Series:** Control cartridge (LL-1A) can be either replaced or repaired at this point. Disassemble cartridge by opening retaining ring (LL-31) and sliding down piston cylinder (LL-11).

- S-61 Series:** Control cartridge (LL-1A) can be either replaced or repaired at this point.
- S-60 Series:** Ordinary service requires only the replacement of the piston/o-ring assembly (LT-4A) and spring (LL-32). Complete rebuilding of the cartridge can be accomplished with repair KIT-LL.  
**S-61 Series:** Ordinary service requires only the replacement of the piston/o-ring assembly (LT-4A) and spring (LL-32). Complete rebuilding of the cartridge can be accomplished with repair KIT-LL.
- S-60 Series:** When re-installing cartridge be sure to align red marking facing back on a normal installation and towards the front on a reverse operation installation.
- Reassemble, reversing above procedure.

## TROUBLE SHOOTING CHART

Problem	Cause	Solution (Follow service instructions)
Faucet runs to long or to short.	Timing	Remove handle - then add washers (LL-28) to stem to shorten time or remove washers to lengthen time.
Faucet drips	Seat washer worn or foreign matter (chips, dirt, solder, etc.) is between washer and seat surface.	Disassemble cartridge and remove piston (LT-4A). Unscrew LL-4 and clean seat washer (LL-37). Check S.S. pin (LL-24) for burr then reassemble.
Faucet runs constantly.	Seat washer not closing on seat surface or seat washer and/or seat surface worn.	Remove piston (LT-4A) and spring (LL-32). Check for burr on pin (LL-24) and check spring. Both LT-4A and LL-32 may have to be replaced. Excessive wear may require cartridge replacement LL-1A.
Water leaks from under handle.	Stem washers worn.	Remove cartridge and replace washers using KIT-LL.
Faucet leaks on or under counter.	Supply housing o-rings worn.	Replace LL-48 o-rings.
Faucet bleeding between hot and cold (SCOT S-60 series only).	LL-71 B check/screens <b>not</b> installed.	Two chrome plated 3/8" check/screens are supplied with every faucet and <b>must</b> be installed.
Faucet bleeding between hot and cold (SCOT S-60 series only).	LL-71 B check/screens <b>are</b> installed.	Replace LL-13 seats.
Handle is loose.	Set screw has loosened.	Tighten set screw.

### 5-Year Limited Commercial Warranty

Symmons warrants to the original purchaser that any Symmons product when used in industrial, commercial or business use will be free of defects in material and workmanship during normal use for a period of 5 years from the date of purchase. At our option, we will either have you send the defective part or product prepaid to us for inspection, or we may elect to send you the replacement part or product without investigation. A replacement for any defective part will be supplied FREE OF CHARGE for installation by the purchaser. Defect or damage caused by the use of replacement parts other than Symmons Genuine Replacement Parts will void this warranty. This warranty excludes product damage due to installation error, product abuse, or product misuse whether performed by a contractor, service company or yourself. Damage to the chrome and/or other decorative finishes on Symmons products may be a result of improper handling or abusive treatment. Finishes should only be cleaned with a soft, damp cloth or sponge. Use of polish, abrasive cleaners, solvents, or acid cleaners will damage the finish and void this warranty.

There are no other express warranties on this product and ALL WARRANTIES OF MERCHANTABILITY AND OTHER IMPLIED WARRANTIES ARE LIMITED IN ACCORDANCE WITH APPLICABLE LAW. SYMMONS INDUSTRIES, INC., EXPRESSLY DISCLAIMS CONTINGENT LIABILITY AND CONSEQUENTIAL DAMAGE OF EVERY KIND. Since some states do not allow limitations on how long an implied warranty lasts or an exclusion or limitation of incidental or consequential damages the above limitation or exclusion may not be applicable. This warranty gives specific legal rights. Other rights may vary from state to state. To obtain warranty service, write to Symmons Industries, Inc., 31 Brooks Drive, Braintree, MA 02184-3804 or call our Customer Service Department at 1-800-SYMMONS. If writing to us, please include proof of purchase, the model number of the product with a brief description of the problem, your name, address and phone number.

SYMMONS INDUSTRIES, INC.

31 Brooks Drive, Braintree, MA 02184-3804

TEL: 1-800-SYMMONS, (781) 848-2250 FAX: 1-800-961-9621, (781) 843-3849

Web site: [www.symmons.com](http://www.symmons.com)

© 2000-2002 Symmons Industries, Inc. Printed in U.S.A. REV 111902

ZV-384 3-Hole  
ZV-385 Folded

